

# Digital Delay / Pulse Generator

DG535 — Digital delay and pulse generator (4-channel)



## DG535 Digital Delay/Pulse Generator

- **Four independent delay channels**
- **Two fully defined pulse channels**
- **5 ps delay resolution**
- **50 ps rms jitter**
- **Adjustable amplitude and offset**
- **Delays up to 1000 seconds**
- **1 MHz maximum trigger rate**
- **Standard GPIB interface**
- **Optional  $\pm 32$  V outputs**

• **DG535 ... \$3995 (U.S. list)**

The DG535 Digital Delay/Pulse Generator provides four precisely timed logic transitions or two independent pulse outputs. The delay resolution on all channels is 5 ps and the channel-to-channel jitter is less than 50 ps. Front-panel BNC outputs deliver TTL, ECL, NIM or variable level ( $-3$  to  $+4$  V) pulses into  $50 \Omega$  or high impedance loads. The high accuracy, low jitter and wide delay range make the DG535 ideal for laser timing systems, automated testing and precision pulse applications.

### Delay Outputs

There are four delay output channels: A, B, C and D. The logic transitions of these outputs can be delayed from an internal or external trigger by up to 1000 seconds in 5 ps increments. The T0 pulse, which marks the beginning of a timing cycle, is generated by the trigger signal. The insertion delay between an external trigger and the T0 pulse is about 85 ns.

Delays for each channel may be "linked" to T0 or any of the other delay channels. For instance, you can specify the delays of the four channels as:

$$\begin{aligned} A &= T0 + .00125000 \\ B &= A + .00000005 \\ C &= T0 + .10000000 \\ D &= C + .00100000 \end{aligned}$$

In this case, when the A delay is changed, the B output will move with it. This is useful, for instance, when A and B specify a pulse and you want the pulse width to remain constant as the delay of the pulse is changed. Regardless of how the delay is specified, each delay output will stay asserted until 800 ns after all delays have timed out. The delays will then become unasserted and the unit will be ready to begin a new timing cycle.

## Pulse Outputs

In addition to the four delay outputs there are four pulse output channels: AB,  $\overline{AB}$ , CD and  $\overline{CD}$ . The leading edge of the AB pulse coincides with the leading edge of A, and the falling edge of the AB pulse coincides with the leading edge of B. For instance, in the previous example, a 50 ns pulse would appear at the AB output and a 1 ms pulse at CD. Pulses as short as 4 ns (FWHM) can be generated in this manner. The complementary outputs ( $\overline{AB}$  and  $\overline{CD}$ ) provide a pulse with identical timing and inverted amplitude.

## Output Amplitude Control

Each delay and pulse output has an independently adjustable offset and amplitude which can be set between -3 V and +4 V with 10 mV resolution. The maximum transition for each output is limited to 4 V. In addition, you can also separately

select 50  $\Omega$  or high impedance termination for each output. For convenience, preset levels corresponding to standard logic families can also be selected. TTL, NIM and ECL levels can each be set with a single key press.

## Triggering

The DG535 can be triggered internally from 1 mHz to 1 MHz with 4-digit frequency resolution. External, single-shot and burst mode triggers are also supported. For power control applications, the DG535 can be synchronized to the AC line. An optional trigger inhibit input allows you to enable or disable triggering with a TTL level input signal.

## $\pm 32$ Volt Outputs

For applications requiring higher voltages, a rear-panel high voltage ( $\pm 32$  V) option is available. This option provides five rear-panel BNCs which output amplified, 1  $\mu$ s pulses at the transition times of the front-panel T0, A, B, C and D outputs. The high voltage option does not affect the function or the timing of the front-panel outputs. The amplitude of the rear-panel outputs is approximately 8 $\times$  the corresponding front-panel output, and the outputs are designed to drive 50  $\Omega$  loads. Since they can only drive an average current of 0.8 mA, charging and discharging the cable capacitance may be the most important current limiting factor to consider when

A timing cycle is initiated by an internal or external trigger. T0 is asserted approx. 85 ns after an external trigger. Outputs A, B, C and D are asserted relative to T0 after their programmed delays. All of the outputs return low about 800 ns after the longest delay. The pulse outputs, AB and CD, go high for the time interval between their corresponding delay channels.

$t_{\text{trig}}$  > 5 ns  
 $t_{\text{cycle}}$  > 1  $\mu$ s + longest delay  
 $t_{\text{ID}}$  < 85 ns  
 $t_{\text{BUSY}}$  < 800 ns + longest delay  
 $t_{\text{A,B,C,D}}$  0 to 999.999 999 999 995 s

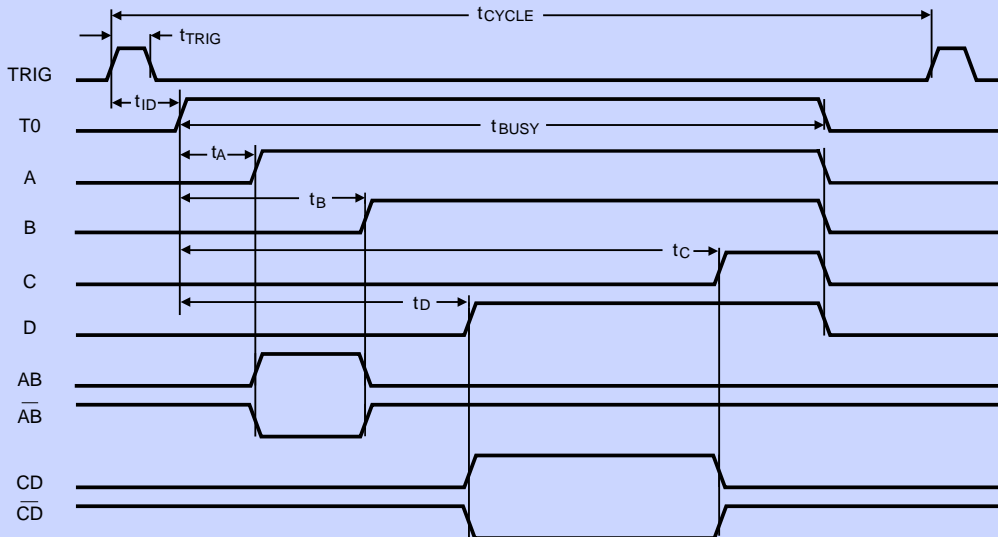

DG535 timing diagram

using them (assuming a high impedance load). In this case, the average current is:  $I = 2V_{\text{tf}}/Z$ , where  $V$  is the pulse step size,  $t$  is the length of the cable in time (5 ns per meter for RG-58),  $f$  is the pulse repetition rate, and  $Z$  is the cable's characteristic impedance (50  $\Omega$  for RG-58).

## Internal or External Timebase

Both internal and external references may be used as the timebase for the DG535. The internal timebase can be either the standard 25 ppm crystal oscillator timebase, or the optional 1 ppm temperature-compensated crystal oscillator (TCXO). The internal timebase is available as a 1 Vpp square wave on a rear-panel BNC. This output is capable of driving a 50  $\Omega$  load and can be used to provide a master timebase to other delay generators. Any external 10.0 MHz reference signal with a 1 Vpp amplitude can also be used as an external timebase.

## Fast Rise and Fall Time Modules

External in-line modules are available to reduce the rise or fall time of the DG535 outputs to 100 ps. These modules use step

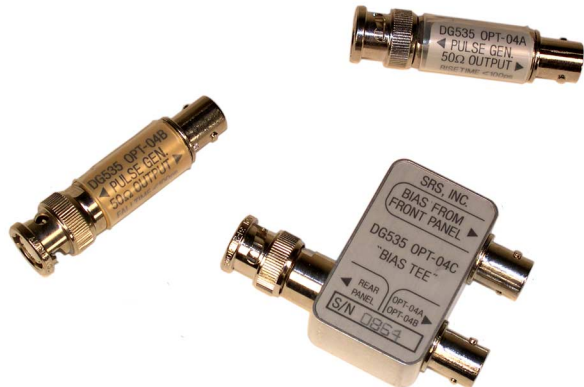

recovery diodes to speed up the rise time (option O4A) or the fall time (option O4B). A bias tee (option O4C) allows these modules to be used with the optional rear-panel outputs to produce steps up to 15 V. For step amplitudes of less than 2.0 V, the fast transition time units should be attached directly to the front panel of the DG535.

## Easy to Use, Easy to Program

All instrument functions can be accessed through a simple, intuitive, menu-based interface. Delays can be entered with the numeric keypad in either fixed-point or exponential notation, or by using the cursor keys to select and change

individual digits. The 20-character backlit LCD display makes it easy to view delay settings in all lighting conditions.

The DG535 comes standard with a GPIB (IEEE-488) interface. All instrument functions can be queried and set via the interface. You can even display the characters the DG535 has received over the interface on the front-panel LCD display. This can be valuable when debugging programs which send commands to the instrument.

## Ordering Information

DG535	Delay/pulse generator w/ GPIB	\$3995
Option 02	$\pm 32$ V rear panel outputs	\$650
Option 03	1 ppm TCXO timebase	\$350
Option 06	Trigger inhibit input	\$250
O4A	100 ps rise time module	\$250
O4B	100 ps fall time module	\$250
O4C	Bias Tee (for 02 & O4A or O4B)	\$100
O5	Dual rack mount tray	\$150



DG535 rear panel (with opt. 02)

**ATE Applications**

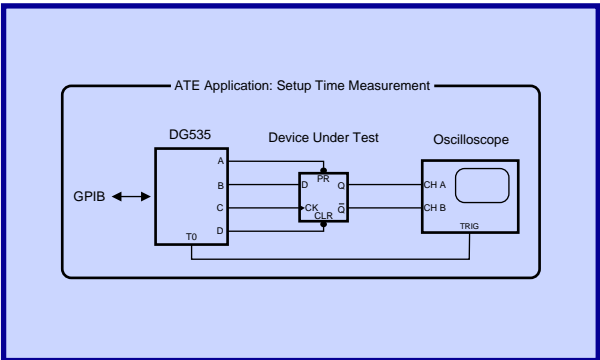

The DG535's versatility, precision and accuracy make it ideal for a wide variety of test and measurement tasks. In this example, the DG535 is used to measure the setup times for the data, preset and clear inputs to a flip-flop. The measurements may be made with picosecond resolution. The logic thresholds for the device under test may be measured using the DG535's adjustable output levels. All measurements may be controlled from the front panel or by a computer via the GPIB interface.

**Laser Timing Applications**

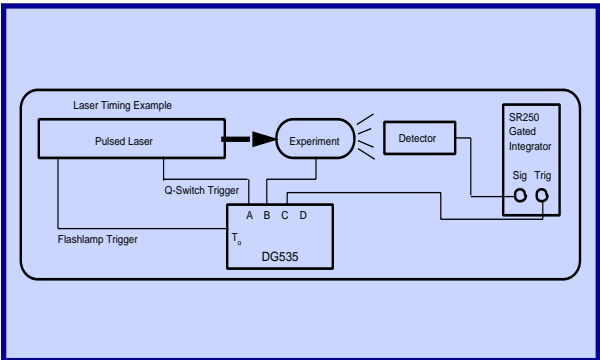

The DG535's four independent outputs make it ideal for laser timing applications. In this example the T0 output of the DG535 fires the flashlamp of a pulsed laser. Its internal rate generator controls the repetition rate of the laser and the overall experimental repetition rate. The A delay output controls the firing of the laser Q-switch. The B delay output can be used to synchronize some aspect of the experiment to the laser pulse, e.g. the application of a voltage pulse, or the triggering of a discharge. Finally, the C delay is used to trigger the gated integrator looking at the detector output. Note that both the B and C delays can be specified relative to the A delay. In this way, as the laser pulse is moved by changing the A to T0 delay, the experimental trigger and the gated integrator trigger will stay fixed relative to the laser pulse.

**Precision Time Control Application**

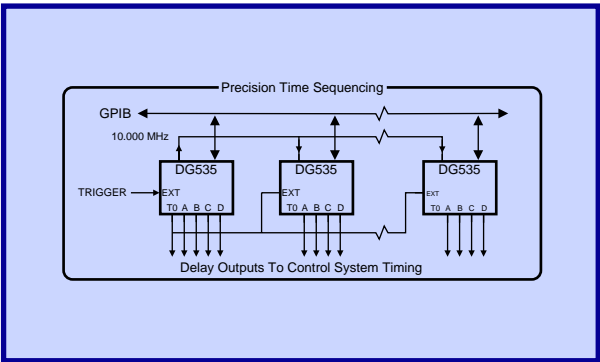

A single DG535 can provide four transitions for precise system timing. Several DG535s may be used if more channels are needed. The 10 MHz reference may be daisy-chained between units so that each DG535 in an experiment uses the same time-base. All of the units may be controlled over the same GPIB bus. The flexible output levels and simple architecture of the pulse/delay generators make it simple and easy to rapidly reconfigure test systems.

**Delays**

Channels	Four independent delay outputs
Range	0 to 999.999,999,999,995 seconds
Resolution	5 ps
Accuracy	1500 ps + timebase error × delay
Timebase	Standard: 25 ppm crystal oscillator Optional: 1 ppm TCXO (opt. 03) External: 10.0 MHz reference input
RMS jitter	<50 ps + $10^{-8}$ × delay (T0 to any output) <60 ps + $10^{-8}$ × delay (ext. trigger to any output)
Trigger delay (typ.)	85 ns (ext. trigger to T0 output)

**External Trigger**

Rate	DC to 1/(1 μs + longest delay)
Threshold	±2.56 VDC
Resolution	10 mV
Slope	Trigger on rising or falling edge
Impedance	1 MΩ + 40 pF or 50 Ω

**Internal Rate Generator**

Rate	Single hot, 0.001 Hz to 1.000 MHz, or line
Resolution	Four digits, 0.001 Hz below 10 Hz
Accuracy	Same as timebase
Jitter	1:10,000
Settling	<2 seconds for any rate change
Burst mode	2 to 32766 pulses per burst at integer multiples (4 to 32767) of the trigger period

**Outputs**

Load	50 Ω or high impedance
Rise time	2 to 3 ns (typ.)
Slew rate	1 V/ns
Overshoot	<100 mV + 10 % of pulse amplitude
Levels	TTL: 0 to 4 VDC (normal or inverted) ECL: -1.8 to -0.8 VDC (normal or inverted) NIM: -0.8 to 0.0 VDC (normal or inverted) VAR: Adjustable offset and amplitude between -3 and +4 VDC with 10 mV resolution. 4 V maximum transition.

Accuracy	±(50 mV + 3 % of pulse amplitude)
Option 02	Rear panel 1 μs pulses corresponding to T0, A, B, C, D outputs with nominal amplitude of 8× the front-panel outputs (1 kHz rep. rate). Output level is reduced by 2V/mA of additional average output current.

**Fast Rise Time (opt. 04A)**

Output amplitude	+0.5 to 2.0 VDC
Output offset	-0.8 VDC (typ.)
Transition time	
Rise (20/80 %)	100 ps (max.)
Fall (20/80 %)	2000 ps (max.)
Pulse aberrations	
Foot	4 % (typ.)
Ring	±5 % (typ.)

**Fast Fall Time (opt. 04B)**

Output amplitude	-0.5 to -2.0 VDC
Output offset	+0.8 VDC (typ.)
Transition time	
Rise (20/80 %)	2500 ps (max.)
Fall (20/80 %)	100 ps (max.)
Pulse aberrations	
Foot	4 % (typ.)
Ring	±5 % (typ.)

**General**

Display	20-character backlit LCD
Computer interface	GPIB (IEEE-488). All instrument functions and settings may be controlled over the interface bus. Interface queue can be viewed from the front panel.
Dimensions	8.5" × 4.75" × 14" (WHD)
Weight	10 lbs.
Power	70 W, 100/120/220/240 VAC, 50/60 Hz
Warranty	One year parts and labor on defects in materials and workmanship

**Accuracy, Jitter, and Drift**

Accuracy, jitter, and drift are three terms often used when discussing delay generators and time measurement equipment. Here we'll discuss what these terms mean, and how they relate to the performance of the DG535.

**Jitter**

Various noise sources in the DG535 modulate the time delay for the outputs causing jitter. Some of these noise sources are common to all channels, others are independent. The distribution of the pulses around the desired time can be approximated by a Gaussian distribution:

$$p(t) = \frac{1}{\sigma\sqrt{2\pi}} e^{-(t-T)^2/2\sigma^2}$$

where:

- p(t) = probability of pulse occurring at time t
- T = time delay for the output (mean value)
- σ = standard deviation of the distribution

The rms jitter of the output is defined as σ, the standard deviation of the pulse delay distribution. In the DG535, the rms jitter is a function of the delay setting. For delays less than 100 μs, the rms jitter is 50 ps. At greater delays the jitter is about 10<sup>-8</sup> of the delay setting. Note that on an oscilloscope display you will not see the rms jitter but will instead observe

the peak-to-peak jitter which is about 4 times worse. The diagram below illustrates the relation between the rms jitter and the apparent peak to peak jitter.

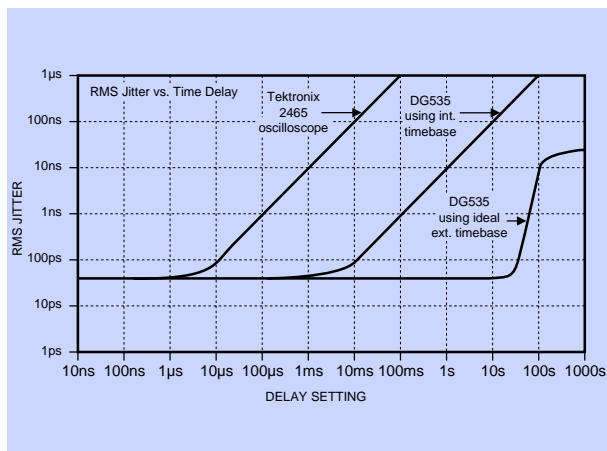

Another factor to consider when trying to observe jitter on an oscilloscope is the jitter in the scope's timebase. For a good 350 MHz scope, the timebase jitter is typically 25 ps rms + 10 ppm of the timebase setting. To show how this affects the apparent jitter seen on a scope, the diagram above plots the rms jitter vs. delay for a Tektronix 2465 oscilloscope, the DG535 with its standard internal timebase, and the DG535 with an ideal, jitter-free timebase. Note that for delays above

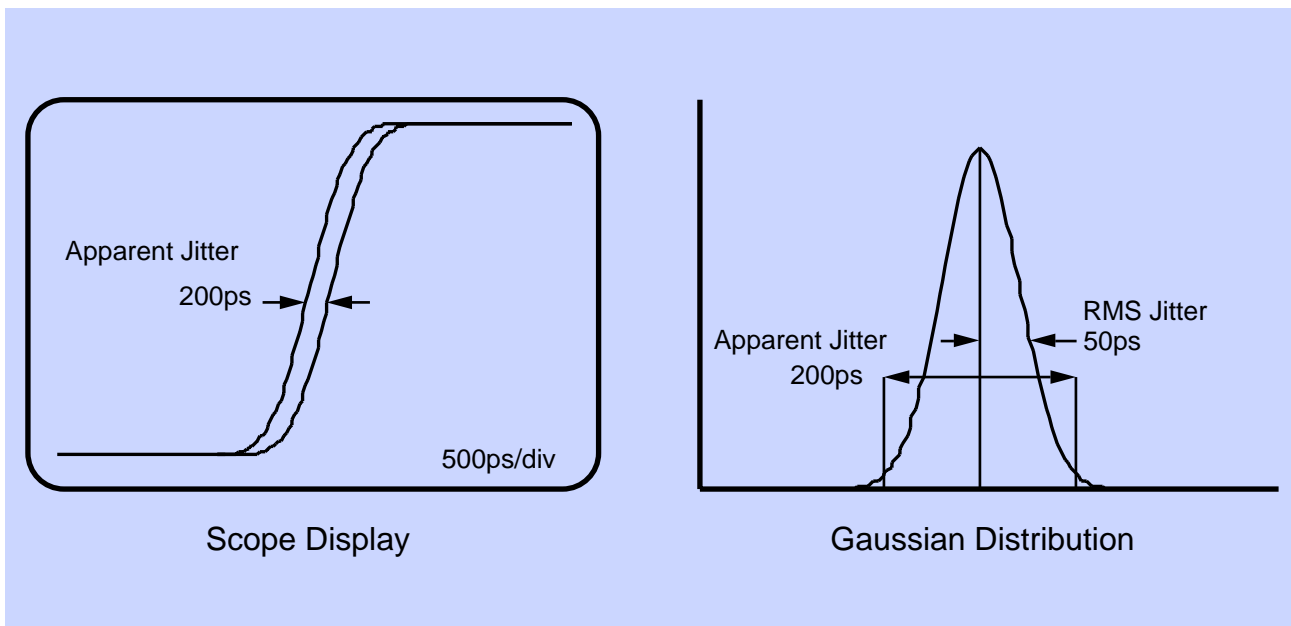

1  $\mu$ s, the DG535's jitter is swamped by that of the scope timebase. To summarize, it is difficult to accurately measure small amounts of jitter with an oscilloscope. The only accurate way to measure jitter is with a time interval counter, such as the SR620.

**Accuracy**

The accuracy of a delay generator is defined as the difference between the mean value of the pulse probability distribution and the nominal front-panel delay setting. In the DG535, the maximum error in the time delay between any two outputs can be expressed as:

$$\text{Error} = 1.5 \text{ ns} + \text{Timebase Error} \times \Delta t$$

where  $\Delta t$  is the time delay between the two outputs. This error is exclusive of time shifts due to slew rates at the outputs. In other words, to accurately measure the error between two outputs they should be set to the same output levels and be driving the same load impedance. The timebase error term depends on which timebase is being used:

Timebase	Error
Standard	<25 ppm, 0 to 50 °C
Option 03	<1 ppm, 0 to 50 °C
External	Source spec + 0.0002 ppm

A time delay of 1.0 ms implies an absolute error of  $\pm 25$  ns,  $\pm 1.5$  ns and  $\pm 0.5$  ns respectively for the standard, optional and external timebases (assuming a 0.01 ppm external source specification). If  $A=100.000 \mu$ s and  $B=100.010 \mu$ s, the error with respect to T0 could be as large as 4.0 ns with the standard timebase, however the error of A with respect to B will be less than 1.5 ns. A graph showing the time error as a function of time delay is shown below. The four curves show the time error for the standard, optional, 0.01 ppm external, and a perfect timebase. The excess error for time delays longer than one second on the ideal external source curve is due to drift in the analog jitter compensation circuits.

**Drift**

The drift of the timebase over several hours is substantially less ( $10\times$  to  $100\times$ ) than the absolute timebase error. The major factor in the timebase drift is the instrument's temperature: after the instrument is warm, the timebase drift is about 0.5 ppm/°C for the standard timebase, and about 0.05 ppm/°C for the optional timebase. The drift between several delay generators in the same experiment may be eliminated by daisy-chaining the reference output from one DG535 to the reference input on the other unit.

